

INSTRUCTION MANUAL

BK PRECISION

3030

.001 Hz to 5 MHz

Sweep/Function Generator



BK PRECISION DYNASCAN
CORPORATION

TEST INSTRUMENT SAFETY

WARNING

Normal use of test equipment exposes you to a certain amount of danger from electrical shock because testing must often be performed where exposed voltage is present. An electrical shock causing 10 milliamps of current to pass through the heart will stop most human heartbeats. Higher voltages pose an even greater threat because such voltage can more easily produce a lethal current. However, voltage as low as 35 volts dc or ac rms should be considered dangerous and hazardous since it can produce a lethal current under certain conditions. Your normal work habits should include all accepted practices that will prevent contact with exposed high voltage, and that will steer current away from your heart in case of accidental contact with a high voltage. You will significantly reduce the risk factor if you know and observe the following safety precautions:

1. Don't expose high voltage needlessly. Remove housings and covers only when necessary. Turn off equipment while making test connections in high-voltage circuits. Discharge high-voltage capacitors after removing power.
2. Use an insulated floor material or a large, insulated floor mat to stand on, and an insulated work surface on which to place equipment; and make certain such surfaces are not damp or wet. Where insulated floor surface is not available, wear heavy gloves.
3. Use the time-proven "one hand in the pocket" technique while handling an instrument probe. Be particularly careful to avoid contacting a nearby metal object that could provide a good ground return path.
4. Always use an isolation transformer to power transformerless "hot chassis" equipment, where one side of the ac power line is connected directly to the chassis. This includes most recent television sets and audio equipment. Without an isolation transformer, the chassis of such equipment may be floating at line voltage (120 VAC, 60 Hz in USA), depending upon which way the 2-wire ac power plug is inserted. Not only does this present a dangerous shock hazard if the chassis is touched, but damage to test instruments or the equipment under test may result from connecting the ground lead of some test instruments to a "hot" chassis. The ground lead of most oscilloscopes and most other test instruments with 3-wire power plugs is at earth ground. The B & K-PRECISION Model TR-110 Isolation Transformer is suitable for most applications.
5. On test instruments or any equipment with a 3-wire ac power plug, use only a 3-wire outlet. This is a safety feature to keep the housing or other exposed elements at earth ground.
6. If possible, familiarize yourself with the equipment being tested and the location of its high voltage points. However, remember that high voltage may appear at unexpected points in defective equipment.
7. Also remember that ac line voltage is present on some power input current points such as on-off switches, fuses, power transformers, etc., even when the equipment is turned off.
8. Never work alone. Someone should be nearby to render aid if necessary. Training on CPR (cardio-pulmonary resuscitation) first aid is highly recommended.

**Instruction Manual
for**



Model 3030

.001 Hz to 5 MHz

Sweep/Function Generator

**BK PRECISION DYNASCAN
CORPORATION**

6460 West Cortland Street
Chicago, Illinois 60635

TABLE OF CONTENTS

INTRODUCTION	1
SPECIFICATIONS	2
CONTROLS AND INDICATORS	4
Front Panel	4
Rear Panel	6
OPERATING INSTRUCTIONS	7
Continuous Run Operation	7
Variable Symmetry Operation	9
Sweep Operation	10
Triggered Output Operation	12
External Control of VCF	13
Combination of Modes	15
CIRCUIT ANALYSIS.....	16
MAINTENANCE AND CALIBRATION	19
Line Voltage Selection	19
Calibration Adjustments	19
WARRANTY INFORMATION	23
Warranty Service Instructions	23
Warranty.....	23
ACCESSORIES.....	24

INTRODUCTION

The **B & K-Precision** Model 3030 is a versatile signal source which combines four functions into one unit - waveform generation, pulse generation (through variable symmetry), frequency sweep operation, and triggered operation. With this versatility, it has a vast number of applications in both analog and digital electronics in the engineering, manufacturing, servicing, educational, and hobbyist fields.

The heart of the function generator is a VCF (voltage-controlled-frequency) circuit that produces precision sine, square, or triangle waves over the .001 Hz to 5 MHz range. This encompasses subaudible, audio, ultrasonic, and RF applications. A continuously variable dc offset allows the output to be injected directly into circuits at the correct bias level.

The sweep generator offers linear or log sweep with variable sweep rate and independent start and stop frequencies. Sweeps can thus be either up or down in frequency. Sweep range is up to 4 decades (10,000:1), permitting applications such as frequency tests through the audio range and beyond with one sweep.

The frequency response of any active or passive device up to 5 MHz can easily be determined.

Triggered operation enables the output to be gated by an external control signal. The unit can be set to output either tone bursts or single cycles in response to the trigger signal. Triggering can also be accomplished from a front panel manual pushbutton. Starting phase of gated sines and triangles is adjustable from -90° to $+90^{\circ}$, and output is always in full cycles.

Variable symmetry of the output waveforms converts the instrument to a pulse generator capable of generating rectangular waves or pulses, ramp or sawtooth waves, and slewed sine waves of variable duty cycle.

In addition to the above features, an external signal may be used to control operating frequency. This is useful in FM applications, or in situations where an externally controlled sweep is desirable. Many functions can be generated simultaneously; this makes possible complex outputs such as gated pulse trains with external or internal sweep.

SPECIFICATIONS

Waveforms	Sine, triangle, square, positive or negative pulse, positive or negative ramp, sweep sync pulse.	Symmetry (Time)	\pm (1% + 10 ns), 1 Hz to 5 MHz, variable symmetry off.
Modes of Operation	Continuous run, sweep (linear or logarithmic), triggered (tone burst or single-cycle), external VCF.	Square Wave	
		Rise and fall times	< 50 ns.
		Overshoot and ringing	< 5% of max. p-p voltage
Frequency Range	0.001 Hz to 5 MHz.	Sine Distortion	< 0.5%, 1 Hz to 100 kHz; All harmonics > 25 dB down, 100 kHz to 5 MHz.
Frequency Accuracy	\pm (1.5% of setting + 1% of full scale) 10 Hz to 1 MHz. \pm (2% of setting + 2% of full scale) .01 Hz to 10 Hz and 1 MHz to 5 MHz.	Triangle Non-linearity	< 1% (Best straight-line method) 1 Hz to 100 kHz.
Variable DC Offset	+10 V to -10 V open circuit. +5 V to -5 V into 50 Ω . Note: Protection circuit automatically clips waveform if dc offset plus signal exceeds maximum voltage.	Sine Frequency Response	< \pm 0.2 dB to 500 kHz. < \pm 1.0 dB to 5 MHz.
		SYNC OUT	Square wave, approximately 4 V peak. 50 Ω output impedance. TTL compatible.
		SWEEP SYNC OUT	3 V pulse coincident with ramp. 600 Ω output impedance.

SPECIFICATIONS

VCF IN (Voltage-controlled frequency)	Approximately 5 V input for 1000:1 linear (10,000:1 log) frequency control.	V:f OUT (Voltage Proportional to Frequency)	0 V to 5 V for 1000:1 linear, 10,000:1 logarithmic frequency range.
Frequency Stability	0.05% of setting for 10 minutes. 0.25% of setting for 24 hours.	Sweep Generator Modes of Operation	Run, hold at start frequency, hold at stop frequency.
Amplitude Stability	0.05% of setting for 10 minutes. 0.25% of setting for 24 hours.	Sweep Rate	10 ms to 100 s.
Symmetry Control	Continuously variable from 5% to 95% duty cycle. Generator frequency is divided by approximately 10 when operating in this mode.	Sweep Limits	Up to 4 decades (10,000:1) logarithmic, 3 decades (1000:1) linear.
Triggered Operation	Requirements: Manual pushbutton depression or external voltage at TRIGGER IN jack. Minimum trigger level +1.6 volts Input: dc coupled, approximately 10 k Ω input impedance.	SWEEP OUT	Ramp waveform when sweep mode is RUN. (0 V to +5 V).
		Power Requirements	100/120/220/240 VAC; 50/60 Hz; 30 Watts.
		Size (HWD)	12.7 x 31.8 x 27.9 cm (5 x 12.5 x 11").
		Weight	4.5 kg (10 lbs).

NOTE: Unless otherwise stated, specifications apply from 10% to maximum output voltage terminated into 50 Ω . Specifications are valid at 25^o C \pm 5^o C after 30 minute warmup. Specifications are subject to change without notice.

CONTROLS AND INDICATORS

FRONT PANEL

(see Fig. 1)

1. **Pilot Light.** Glows when unit is on.
2. **START FREQ Control.** Selects the basic operating frequency; also sets the starting frequency for sweep operation. Control is composed of two dials:
 - a. Outer dial provides coarse adjustment in steps of one-tenth of the RANGE-Hz (19) setting. Full clockwise position gives $1.0 \times$ RANGE-Hz setting.
 - b. Inner vernier dial fine tunes frequency above outer dial setting, in hundredths of the RANGE-Hz setting. With this dial set to zero, frequency is RANGE-Hz reading times outer dial position. NOTE: Dial scales are linear and not applicable if running in LOG mode.
3. **STOP FREQ Control.** Sets the sweep terminating frequency; instrument will sweep to this frequency and return to start a new sweep. Selection is similar to the START FREQ control (2), and is affected by both the RANGE-Hz control (19) and the LIN/LOG switch (4).
4. **LIN/LOG Switch.** Selects linear or logarithmic characteristics for VCF circuit in all modes.
5. **TRIGGERED OUTPUT Switches.** These two switches select continuous run or triggered operation as follows:
 - a. RUN depressed, GATE released or depressed: Instrument runs continuously at the frequency selected, or sweeps according to setting of sweep switches (7).
 - b. GATE depressed, RUN released: Gated tone burst operation; gener-

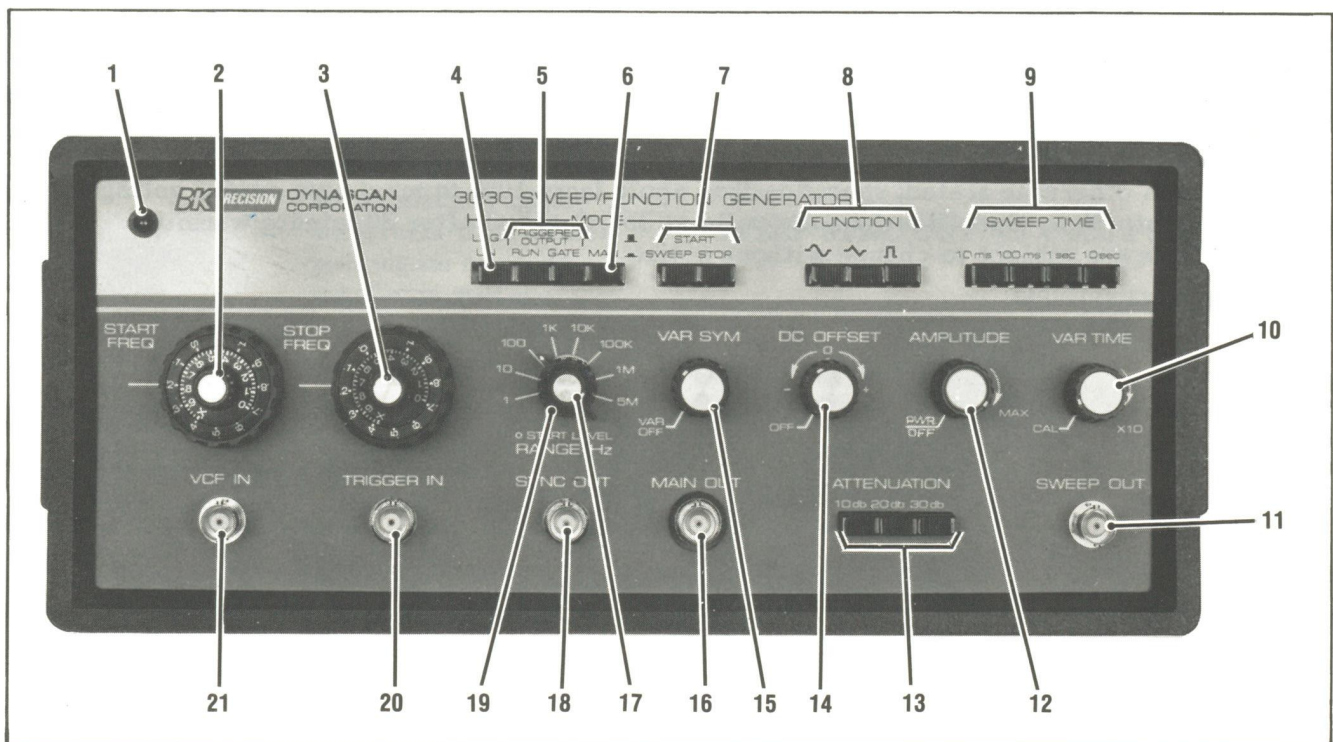

Fig. 1. Front panel controls and indicators.

- ates output for duration of trigger signal from TRIGGER IN jack (20) or MAN switch (6).
- c. RUN and GATE both released: Single-cycle operation; instrument outputs one cycle for each trigger signal from TRIGGER IN jack (20) or MAN switch (6).
6. **MAN Switch.** Gates the output manually during triggered operation.
 7. **Sweep Switches.** Select continuous run or frequency sweep operation as follows:
 - a. SWEEP released, STOP released or depressed: Instrument runs continuously at the frequency selected by the START FREQ control (2).
 - b. SWEEP and STOP both depressed: Instrument runs continuously at the frequency selected by the STOP FREQ control (3).
 - c. SWEEP depressed, STOP released: Instrument sweeps from frequency selected by START FREQ control (2) to that selected by STOP FREQ control (3). Sweep can be either up or down in frequency.
 8. **FUNCTION Switches.** Select one of three output waveforms: square, triangle, or sine wave.
 9. **SWEEP TIME Switches.** Select the amount of time to sweep from the START FREQUENCY to the STOP FREQUENCY in four steps from 10 ms to 10 sec. Fine tuning above each step is provided by VAR TIME control (10).
 10. **VAR TIME Control.** Provides continuous variation between steps of SWEEP TIME (9). In the CAL position, sweep time is given directly by switch setting; in the X10 position, sweep time is ten times the switch setting.
 11. **SWEEP OUT Jack.** Provides a 0 to 5 volt ramp running at the sweep time rate. During continuous run operation, it is held at one of two levels: 0 volts with unit running at START FREQUENCY and 5 volts when running at STOP FREQUENCY.
 12. **PWR OFF/AMPLITUDE Control** Turns instrument on and off. Varies the peak-to-peak amplitude of MAIN OUTPUT (16) from maximum (fully clockwise) to 20 db below maximum.
 13. **ATTENUATION Switches.** Provide 10 db, 20 db, or 30 db steps of attenuation of MAIN OUTPUT. Can be used together to give any multiple of 10 db attenuation from 0 to 60 db. The AMPLITUDE control (12) can be used in conjunction with these switches to provide a total attenuation of 80 db.
 14. **DC OFFSET Control.** Varies the dc level of MAIN OUTPUT (+10 to -10 V open circuit, +5 to -5 V into 50 Ω). Zero dc level is obtained by switching this control OFF.
 15. **VAR SYM control.** Varies symmetry of output from 19:1 to 1:19. The VAR OFF position gives 1:1 symmetry.
 16. **MAIN OUTPUT.** Maximum 20 V p-p open circuit, 10 V p-p into 50 Ω termination.
 17. **START LEVEL Control.** Varies the start phase of sine and triangle waves from -90° to $+90^\circ$.
 18. **SYNC OUT Jack.** 0 to 4 volt square wave coincident with the main outputs.
 19. **RANGE-Hz Control.** Provides decade changes in frequency. Multiplication of the selected range times the START FREQ control (2) setting gives the actual output frequency.
 20. **TRIGGER IN Jack.** Input for external gating or triggering. When the applied signal goes above 1.6 V the instrument is triggered. The signal must go below

CONTROLS AND INDICATORS

approximately 1.3 V to remove the triggered condition. Maximum input is ± 12 V.

21. **VCF IN Jack.** Allows frequency control by external voltage. VCF operates over 0 to 5 volt range. Voltage applied at this jack is summed with voltage from front panel controls; result determines the VCF operating point. AC voltages about zero will frequency modulate the output around the selected frequency.

REAR PANEL

(see Fig. 2)

22. **Fuseholder.**

23. **V:f OUT Jack.** Provides a voltage proportional to the output frequency. Approximately 0 to 5 volt range.

24. **SWEEP SYNC OUTPUT Jack.** Provides a +3 V pulse during the reset interval between sweeps.

25. **LINE VOLTAGE SELECT Switches.** Slide switches which select 100/120/220/240 volt ac line voltage. See MAINTENANCE AND CALIBRATION section for details.

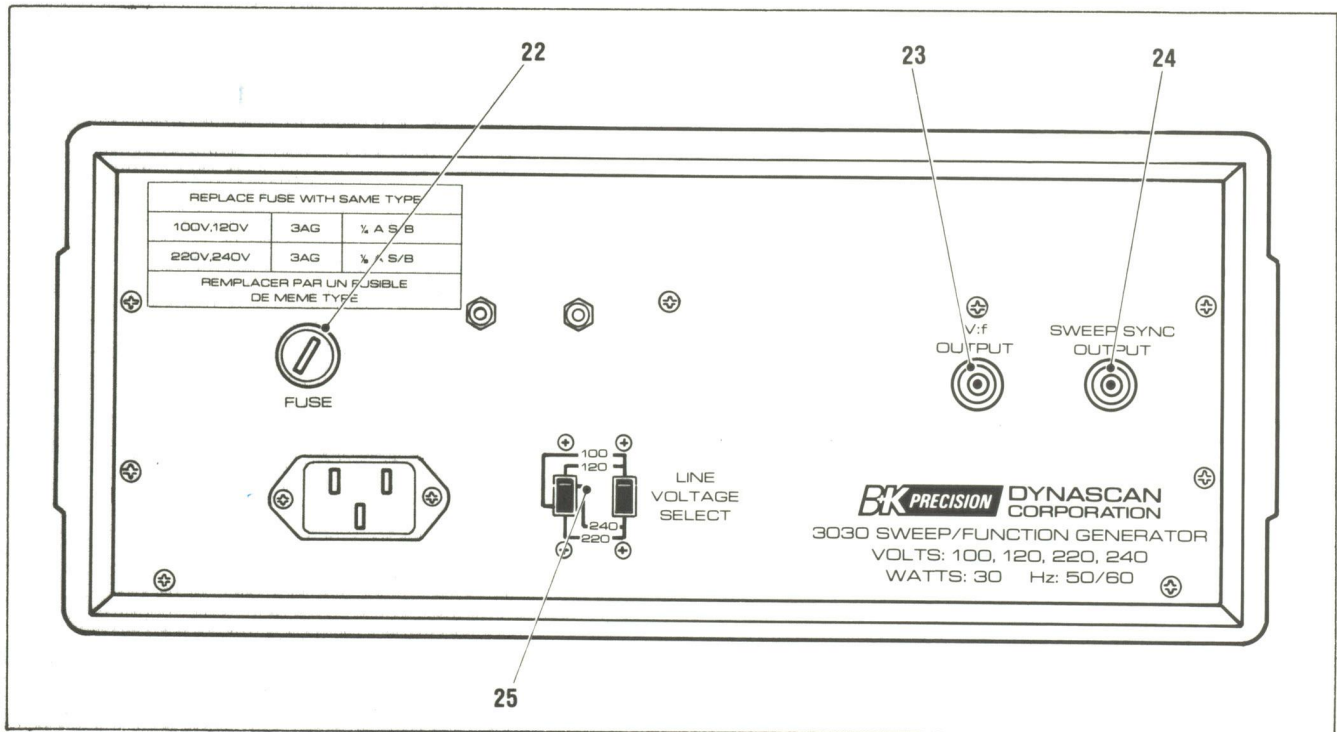

Fig. 2. Rear panel.

OPERATING INSTRUCTIONS

The Model 3030 Sweep/Function Generator is capable of generating a variety of output waveforms. The most benefit and satisfaction can be gained from the instrument by fully understanding its capabilities and versatility and becoming proficient in its operation. One of the best ways to initially gain this familiarization is to connect the generator to an oscilloscope, observe the waveforms, and notice the effects of the various controls on the waveforms. Use this manual as required for reference until becoming accustomed to the operating procedures.

CAUTION

Before connecting unit to line voltage, make sure that LINE VOLTAGE SELECT switches (25) on rear panel are set properly, and that the fuse is the proper size. See the MAINTENANCE AND CALIBRATION section of this manual for details.

CONTINUOUS RUN OPERATION

Procedure

1. Plug ac power cord into outlet and turn power on with the PWR OFF/AMPLITUDE control (12).

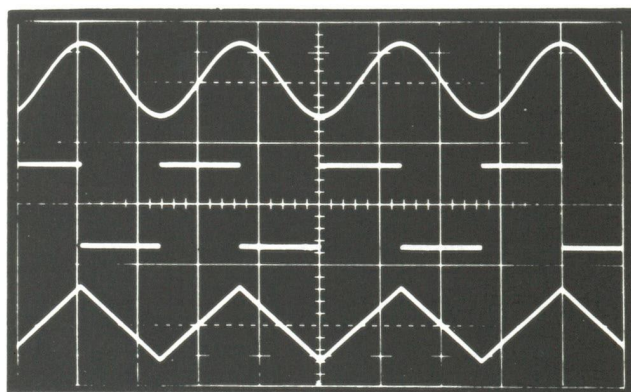

Fig. 3. Sine, square, and triangle waveforms.

To make sure that the output is symmetrical and unaffected by the sweep generator, triggering, or other controls, set the following controls as specified:

CONTROL	POSITION
TRIGGERED OUTPUT (5):	
RUN	Depressed
GATE	Released
Sweep (7):	
RUN	Released
DC OFFSET (14)	OFF
TRIGGER IN (20)	No Connection
VCF IN (21)	No Connection
VAR SYM (15)	VAR OFF

1. Select the desired frequency range with the RANGE-Hz control (19).
2. Select either linear or logarithmic frequency scale with LIN/LOG switch (4). Since the frequency dials are scaled linearly, the most accurate frequency selection (without a counter) is provided by linear selection.
3. The START FREQ control has two scales. The outer sets to tenths of the RANGE-Hz (19) setting, providing coarse adjustment in 11 steps. The inner vernier sets to hundredths, for fine adjustment between steps. The output frequency is the product of the START FREQ setting and the RANGE-Hz setting.

For example:

- a. A START FREQ setting of .59 (.5 on outer dial, 9 on inner dial) and a RANGE-Hz setting of 100 results in an output of $.59 \times 100$ Hz, or 59 Hz.
- b. A START FREQ setting of 1.06 (1. on outer dial, 6 on inner dial) and a RANGE-Hz setting of 100K gives 106 kHz (1.06×100 kHz).

OPERATING INSTRUCTIONS

- c. A START FREQ setting of .40 (.4 on outer dial, 0 on inner dial) and a RANGE-Hz setting of 5M produces 2 MHz (.40 x 5 MHz).
6. Select sine, square, or triangle wave by pressing the corresponding FUNCTION switch (8). Fig. 3 illustrates the output waveforms and their phase relationships.
7. Connect a cable from MAIN OUTPUT (16) to the desired signal injection point.

CAUTION

Always make ground connections only to 0 volt points in the circuit under test. All inputs and outputs are connected to earth ground via the 3-wire plug, and connection to a voltage point may damage the equipment being tested.

8. Adjust the output to the desired amplitude with the AMPLITUDE control (12) and ATTENUATION switches (13). The AMPLITUDE control provides from 0 to 20 db attenuation, and the switches give 10, 20, or 30 db steps, or any combination thereof. Total attenuation possible is therefore 80 db.

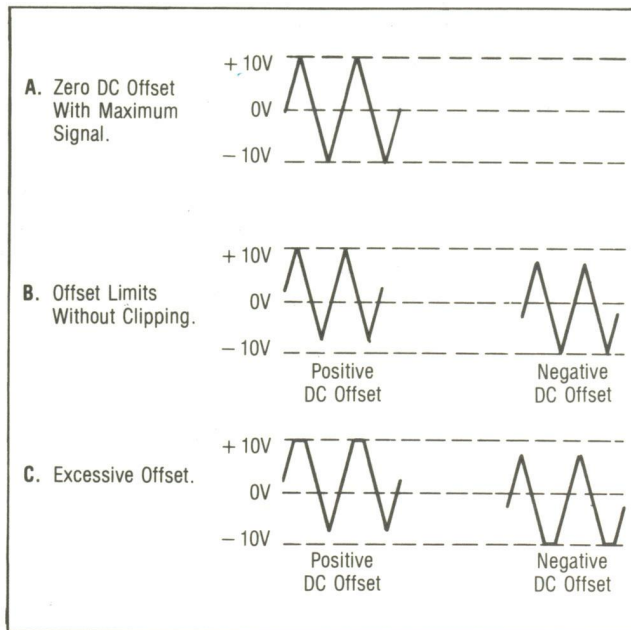

Fig. 4. Use of DC OFFSET control.

9. A positive or negative dc component can be added to the output signal by use of the DC OFFSET control (14), as required by the circuit into which the signal is being injected. Setting this control to OFF sets the offset to zero.
10. A fixed amplitude 0-4 volt square wave is available at the SYNC OUT jack (18). This signal is compatible with TTL circuits, and is unaffected by the AMPLITUDE or DC OFFSET controls. It is always a square wave, regardless of waveform type selected.

Considerations

Knowledge of the following factors is essential for proper operation of the instrument:

1. The DC OFFSET control can provide up to ± 10 volts open-circuited, or ± 5 volts into 50Ω . Remember that the combined signal swing plus dc offset is also limited to ± 10 volts open-circuited, or ± 5 volts into 50Ω . Clipping occurs slightly above these levels. Fig. 4 illustrates the various operating conditions encountered when using dc offset. If the desired output is large or if a large dc offset is used, an oscilloscope should be used to make sure that the desired combination is obtained without clipping. The probability of clipping is reduced by keeping the AMPLITUDE control in the lower half of its adjustment range when possible.
2. To set the DC OFFSET to a specific dc voltage, depress the FUNCTION switches slightly so that all switches are released (all buttons out). This removes signal from the output and leaves the dc only. Measure the dc output on an oscilloscope or dc voltmeter and adjust the DC OFFSET control for the desired value. NOTE: The ATTENUATION switches affect the dc offset as well as the waveform; dc levels must be kept in mind when changing step attenuator settings. It is advisable to adjust dc level after attenuation has been set.

3. It is easier to accurately set the START FREQ control if outer dial settings other than S are used. Although the dial rotation overlaps ranges, it is usually not necessary to use this setting. Just change to a lower range and use a higher dial setting.
4. If the outer dial is set to S, the inner dial no longer represents hundredths of the RANGE-Hz setting. Rather, rotation of this dial now covers the entire VCF range for the particular RANGE-Hz setting.
5. The source impedance from the MAIN OUTPUT is 50 Ω , but the output may be fed into any circuit impedance. However, the output level varies in proportion to the terminating impedance. If it is desired to maintain a constant output level while injecting signal into various circuits with different impedances, a constant terminating impedance is necessary. When the generator output is connected to a coaxial connector on the equipment under test, it usually presents a 50 Ω terminating impedance. Most

other circuit points are usually moderate to high impedance. A reasonably constant terminating impedance may be maintained while injecting signal into moderate and high impedance circuits (500 Ω and up) by adding a coaxial tee in the output cable and connecting a 50 Ω termination to one leg. Remove the 50 Ω termination when injecting into a 50 Ω circuit. Also keep dc considerations in mind. If dc voltage is present at the signal injection point, the DC OFFSET should be set to match the circuit voltage, or a blocking capacitor may be required to avoid dc loading with 50 Ω .

6. When using the higher output frequencies or the square wave output, terminate the cable in 50 Ω to minimize ringing. Keep the cables as short as possible.
7. To set output amplitude to a specific level, measure peak-to-peak amplitude on an oscilloscope.

VARIABLE SYMMETRY OPERATION

In a symmetrical square, sine, or triangle wave, the positive and negative transitions are of equal duration, or 1:1 ratio. This is the condition when the VAR SYM (variable symmetry) control (15) is set to the VAR OFF position. When this control is rotated, the ratio of positive duration to negative duration is varied from 19:1 to 1:19. Square waves can be stretched into rectangular waves or pulses, triangle waves can be stretched into ramp or sawtooth waves, and sine waves can be stretched into a distorted waveshape called a slewed sine wave. Fig. 5 illustrates the effects of symmetry variation. In each case, the upper waveshape of the two shows the output for nearly full counterclockwise rotation of the VAR SYM control. The lower indicates the effects of nearly full clockwise rotation.

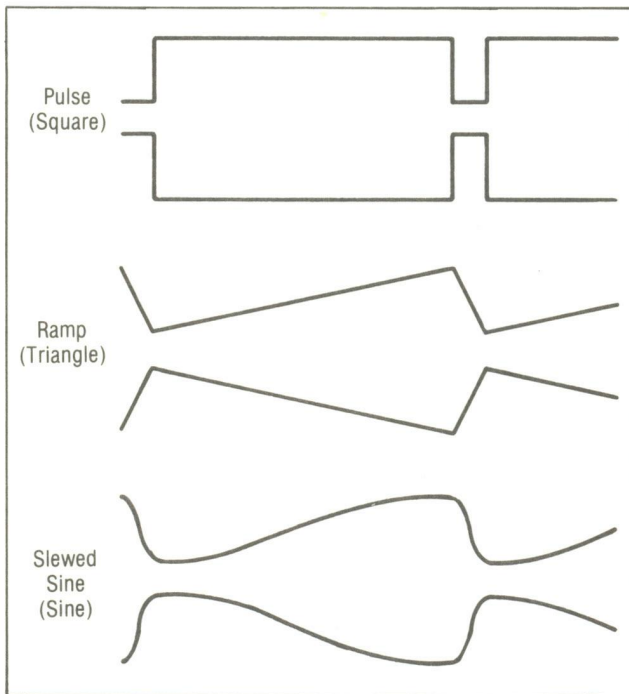

Fig. 5. Effects of symmetry variation.

Procedure

8. Set up generator as described for function generator operation. Display the output on an oscilloscope.

OPERATING INSTRUCTIONS

9. Select the desired type of waveform. Press the square wave button for pulses, triangle button for ramp waves, or sine button for slewed sine waves.
10. Rotate the VAR SYM control out of the VAR OFF position. This action will reduce the frequency of the output by a factor of approximately 10. As the dial is rotated clockwise, the symmetry of the output waveform will change as described above. Adjust for desired pulse (ramp) width.
2. Select linear or logarithmic sweep with the LIN/LOG switch (4).
3. Select the sweep range with the RANGE-Hz control (19). Sweep can occur between any two frequencies accessible with one RANGE-Hz setting.
4. The start frequency is selected by setting the START FREQ control to the desired value. The unit need not be running in continuous mode to make this selection; however, if greater accuracy is desired, or if the unit is running in LOG mode, a frequency counter must be used. This makes it necessary to set for continuous operation while selecting.

Considerations

1. Rotation of VAR SYM from one end to the other varies symmetry from 19:1 to 1:19, positive/negative ratio. Equal symmetry occurs at about the halfway point of rotation, although switching to VAR OFF achieves this condition more accurately.
2. Beyond the initial 10 times reduction, no further frequency deviation occurs as a result of symmetry variation. However, since this is an approximate reduction, the use of a frequency counter is advised if accurate frequency adjustment is to be made.
3. When observing ramp waves or slewed sine waves with an oscilloscope, it may be easier to measure the time periods on the scope using the square wave mode, then switch to the desired operating mode.
4. For ease and accuracy in pulse measurement, use a higher sweep speed on the oscilloscope to expand the pulse width for measurement, then reduce sweep speed to measure the repetition rate.
5. The stopping frequency is selected by the STOP FREQ control (3). This control encompasses roughly the same range as the START FREQ control, and is operated in similar fashion. STOP FREQUENCY setting is also affected by the RANGE-Hz and LIN/LOG controls.
6. As with START FREQ, the stop frequency may be selected regardless of the current operating mode; However, if greater accuracy is needed, or if the unit is running in LOG mode, the use of a counter makes it necessary to run the unit in STOP FREQ mode when selecting. This is done by engaging both Sweep (7) switches (SWEEP and STOP).
7. To run the unit in sweep mode, the SWEEP switch must be engaged and the STOP switch must be released.
8. The SWEEP TIME switches (9) and VAR TIME control (10) set the amount of time required for the unit to sweep from the START FREQUENCY to the STOP FREQUENCY. The switches set the minimum sweep time, which can be expanded by the VAR TIME control. Effective range is approximately 10 ms to 100 seconds. Determination of sweep time can best be made when unit is running in sweep operation.

SWEEP OPERATION

Procedure

1. Set up equipment as for continuous run operation.

Considerations

1. Separate controls for START and STOP FREQUENCIES make possible sweeping in either direction, either up or down in frequency.
2. Maximum sweep range is 3 decades (1000:1) using linear sweep; 4 decades (10,000:1) with logarithmic.
3. SWEEP SYNC OUTPUT (24) on the rear panel provides a +3 volt pulse during the reset interval between sweeps. This is useful for synchronization of other test instruments, or as a blanking pulse for oscilloscopes.
4. V:F OUT (23) and SWEEP OUT (11) both provide signals which may be used with an oscilloscope to determine the sweep

speed at high sweep rates. Simply connect either of these outputs to a scope and measure the ramp interval on the screen. The SWEEP OUT signal is always a 0 to +5 volt linear positive-going ramp, unaffected by changes in sweep range. The magnitude of the V:F OUT ramp, however, is dependent on the frequencies swept, and gives direct visual information about sweep range and direction. See Fig. 6. In the figure the same SWEEP OUT signal is present for any of the three V:F OUT displays.

5. Setting of sweep time is dependent upon the frequencies being swept. A lower repetition rate is required for sweeping of low frequencies, and a high rate may be used for sweeping higher frequencies. The sweep rate must be low enough to allow a few cycles of generator output at the low frequency end of the sweep before the generator sweeps into mid-range. The LOG sweep is sometimes preferred because it does not sweep through the low frequencies as rapidly. A higher sweep rate reduces flickering of the oscilloscope for viewing convenience.

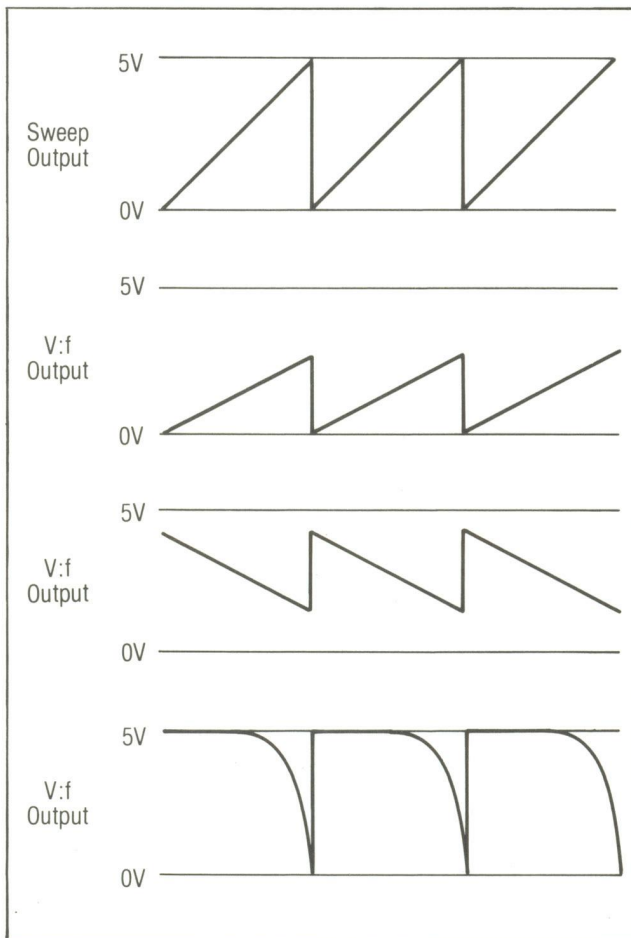

Fig. 6. SWEEP and V:f outputs.

One of the main uses of a sweep generator is checking the frequency response of amplifiers, tone controls, filters, and other frequency sensitive devices. The presence of the linear SWEEP OUT ramp permits observation of response characteristics directly on an oscilloscope in X-Y mode. Output amplitude can be plotted on the vertical axis, and frequency on the horizontal.

The basic set-up is shown in Fig. 7. If the linear sweep method is used, each horizontal graticule marking corresponds to a particular frequency, with equal scale increments representing equal frequency increments.

If the log sweep method is employed (as is appropriate for 20 Hz to 20 kHz audio sweeps), the frequency increments vary in logarithmic fashion along the horizontal axis. For log display, it is important that the horizontal scope input be connected to the *linear* SWEEP OUT ramp rather than V:F OUT. The ramp present at V:F OUT is logarithmic in LOG

4. Rotate the START LEVEL control (17) so that the waveform (sine or triangle) starts at the desired point on the positive slope.

Considerations

1. On and off trigger thresholds are +1.6 volts and +1.3 volts, respectively. Signal must go above +1.6 volts to turn output on, and below approximately +1.3 volts to switch it off.
2. Output can be gated manually using the front panel MAN switch (6).
3. The START LEVEL control varies the start phase of the waveform from -90° to $+90^{\circ}$. 0° is obtained at approximately the center of rotation. To set exactly for 0° , display the output on an oscilloscope. Expand the waveform display to the largest visible size, and center it vertically. Adjust the START LEVEL control until the starting point is at the exact vertical center of the waveform.
4. The gated output is always in full cycles, always ending at the point selected by the START LEVEL control.

Single-Cycle Operation

Procedure

1. Set-up is the same as for gated operation, except that both the RUN and GATE switches are released to enable the single-cycle mode.

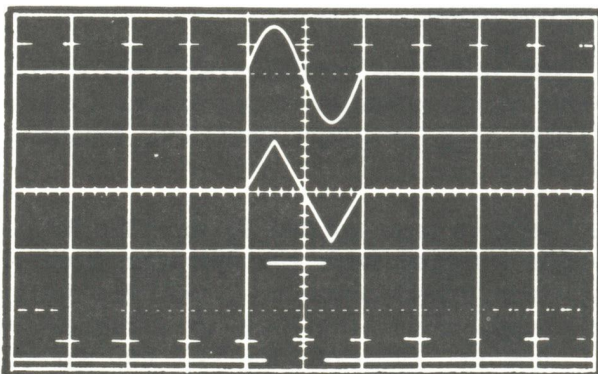

Fig. 9. Single-cycle waveforms.

2. Once this mode is enabled, any excursion by the trigger signal above the threshold value will produce a single cycle of the selected waveform. The output will then remain off until the next positive-going threshold crossing.
3. Each push of the front panel MAN switch (6) will result in a single cycle of output.
4. Starting level for sines and triangles can be adjusted to any positive-slope point by means of the START LEVEL control. The single cycle will start at this point and end at the same point on the next cycle.

EXTERNAL CONTROL OF VCF

The internal VCF (voltage-controlled frequency) circuit of the 3030 has as its inputs a number of front-panel controls which have already been discussed. In each case, the particular control involved presents a variable voltage to the VCF. The sum of these various control voltages is processed by the VCF to produce a certain output frequency.

The VCF IN jack (21) provides direct access for an external control voltage which is in turn summed with all other control inputs to the circuit. This allows external frequency control, making possible three modes of operation:

1. Control by a fixed dc voltage, producing a specific output frequency.
2. Control by an ac voltage, resulting in FM modulation.
3. Control by a ramp (or other type waveform) providing externally controlled sweep generator operation.

Control by Fixed DC Voltage

1. Set up as for regular continuous run operation, setting operating frequency using front-panel controls.

OPERATING INSTRUCTIONS

2. Connect an external voltage to the VCF IN jack (21).
3. Since this voltage input is combined with those of the front panel, an input of 0 volts dc has no effect on the output frequency.
4. As the voltage is deviated around zero in the positive or negative direction, the output frequency increases and decreases accordingly.

Frequency control by external dc voltage is useful in programmed frequency selection. A set of two or more specific frequencies may be programmed by using multiple dc voltage values which may be selected by a switch or electronic switching circuits. This type of operation would be desirable in production testing where signals at several specific frequencies are required for various tests. To maintain the original accuracy each time the operation is repeated, the START FREQ control must be accurately set to the same position. Probably the easiest way to assure this common dial setting is to set both the inner and outer dials to their lower ends (inner dial 0, outer dial S). The external voltage then exercises complete frequency control, and negative polarity voltages are not required.

Control by AC Voltage—FM Modulation

1. Set up as described for function generator continuous run operation. Use frequency and amplitude controls to set the carrier as desired.

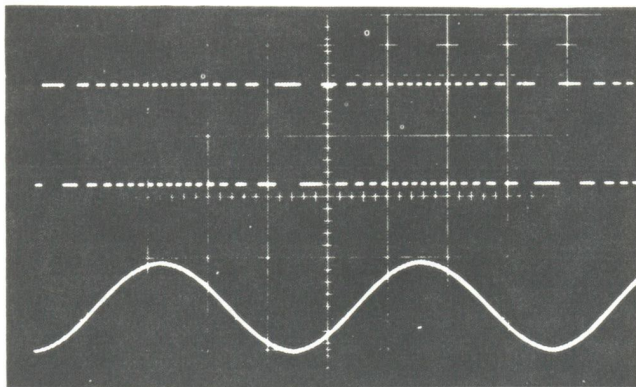

Fig. 10. FM modulation.

2. Connect an ac modulating signal with no dc component to the VCF IN jack.
3. Adjust the amplitude of the ac modulating signal for the desired frequency deviation.

An example of FM modulation is given in Fig. 10. In the figure, a square wave carrier is being modulated by a sinusoidal voltage.

Control by Ramp Voltage

1. Set up as for function generator continuous run operation.
2. Set START FREQ control to its lowest position (inner dial 0, outer dial S). This is not absolutely necessary but enables the external voltage to completely control the frequency range.
3. Apply a positive ramp (or other waveform) voltage to VCF IN. The amplitude of the external sweep signal now determines the sweep width, and its frequency determines the sweep rate. NOTE: The RANGE-Hz and LIN/LOG controls still affect the frequencies and linearity of the output sweep.
4. Negative sweeps can be obtained by setting START FREQ to its highest setting and applying a negative-going external ramp.

An example of an externally controlled sweep is shown in Fig. 11.

Considerations

The following considerations apply to all modes of operation involving external control of the VCF (voltage-controlled frequency) circuit.

1. Any voltage applied to the VCF IN jack is summed with the voltages from the front panel controls. A positive voltage input drives the VCF to a higher frequency. However, the VCF can never be driven beyond its range limits (the highest and lowest frequencies that can be

attained on a particular RANGE-Hz setting).

2. On any RANGE-Hz setting, frequency range limits are spanned by approximately 0 to +5 volts at the internal VCF input (in both linear and log modes). Therefore, the VCF IN range needed to cover the band is a five-volt spread somewhere between about +5 and -5 volts dc. For example, if the unit is running in normal continuous mode, and the START FREQ control is set near its upper limit, then an external VCF input of -5 to 0 volts dc covers the available frequency range. In this case, if the VCF voltage goes slightly above zero, it brings the output frequency up to the high range limit. Further positive excursions produce no change.

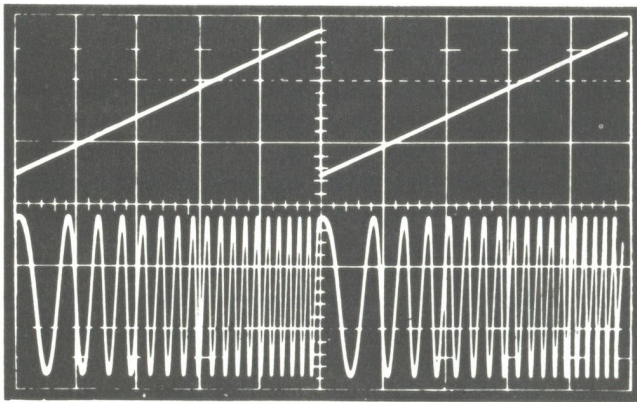

Fig. 11. Frequency control by external ramp.

3. The START FREQ control is usually set to the low end of its rotation when using external VCF control. This reduces the dialed VCF voltage to zero, and allows the external VCF voltage to exercise complete control. It also reduces the effects of dial setting inaccuracy.
4. The output frequency is dependent on the LIN/LOG and RANGE-Hz settings.

COMBINATION OF MODES

The Model 3030 may be operated in many of its modes simultaneously. Following is the list of modes of operation that may be combined, if desired. This list excludes variable symmetry operation, which can be used with any mode or combination of modes as given below. In each of the combinations, sine, square, or triangle wave output may be used.

Continuous/External VCF

Gated/Sweep

Gated/External VCF

Single-Cycle/Sweep

Single-Cycle/External VCF

External VCF/Sweep

Gated/External VCF/Sweep

Single-Cycle/External VCF/Sweep

CIRCUIT ANALYSIS

The basic waveform of the 3030 is a triangle wave, generated by means of two constant current sources and a timing capacitor. The capacitor is alternately charged positively and negatively, resulting in a very linear triangular ramp. The three output waveshapes are derived from this triangle. Refer to the block diagram, Fig. 12, for overall analysis and to the separately supplied schematic diagram for specific circuit details.

Main Generator Loop

0 to 5 volts dc is applied at the VCF input R9, or at R8 or R221 from the START FREQ or STOP FREQ controls, respectively. The resulting currents are summed at pin 3 of U4 together with a small current from the 1000:1 calibration adjustment. The +1 to +7 volts at the output of U4 is level shifted by Q1 to -11.5 to -6.5 volts at the bases of U7A, B, and C.

Ramp speed, and thus output frequency, is directly dependent on the amount of current through U7B. Linear or logarithmic negative feedback from the collector of U7B to the + input of U4 maintains dial linearity or creates the logarithmic response when in the LOG mode.

The current through U7A and C tracks that through U7B. U7C is the negative current source for the timing capacitor, while U7A is part of the current mirror for the positive current source (U7D).

Resistive current divider R18, R19, and R20 provides linear feedback from the collector of U7B to the + input of U4. This divider reduces the current applied to the + input of U4 while allowing the collector current of U7B to equal that of the negative current source of U7C. Equalizing these currents provides maximum precision by utilizing equal operating points.

When in LOG, the current divider is replaced with an active logarithmic amplifier consisting of Q206A and Q206B and FET

Q205. As with the resistive current divider, the current from U7A is equal to that of U7C, the negative current source, while the current to the + input of U4 is the much lower required value.

U7E acts as a current mirror; tracking is accomplished with negative feedback provided by Q5 and Q6. U7D provides the positive current source by matching the current in the current mirror.

The level detector alternately sinks each of the two current sources through diode bridge D11, D12, D13, and D14. Thus, as one source sends current to the detector, the remaining source linearly charges the range selected timing capacitor C15.

Variable symmetry is obtained by switching the VAR SYM control into the emitter legs of U7A and U7C. This potentiometer produces equal and opposite changes in the current from each of the two sources. The result is an expansion of one side of the triangle, and a corresponding compression of the other.

Q9, Q10, and Q11 are a unity gain buffer with a very high input impedance. This buffer prevents loading of the current sources to provide a very linear triangle. The input stage, FET Q9, is a source follower, and Q11 is an emitter follower.

The level detector-bistable switch, Q12, is a differential amplifier with Q13 providing a constant current. The reference levels, ± 5 V, at the base of Q12B are determined by R53, R54, and R62, depending on the state of diode bridge D17 and D18. D15 and D16 limit the collector voltage excursions to improve high frequency response.

The level detector collectors differentially drive a non-saturating current-mode switch, Q14 and Q15. One switch output, Q15, drives the level detector reference gate and the current source bridge. The output of Q14 is fed to the Q23-Q24 amplifier and used as the square wave output.

The SYNC OUT signal is provided by Q17 and Q18. Q17 shifts the square wave to TTL levels and Q18 provides buffering.

Capacitance Multiplier

U8 is a capacitance multiplier used on the 1 Hz and 10 Hz ranges only. It inverts and amplifies the triangle and applies it to the opposite end of the 10 μF and 100 μF timing capacitors, making them appear to be 100 μF and 1000 μF , respectively.

Sine Converter

The basic triangle wave is converted to a sine wave with a bipolar diode shaping network. The triangle is applied directly to the three diode bridges, D24, D25, and D26. As the triangle rises, each diode bridge switches in succession, causing the output of the network to form a sine wave.

Waveform Switches

These switches apply the appropriate waveform to the preamplifier. When TRIANGLE is selected, the basic triangle generated at C15 and buffered by Q9, Q10, and Q11 is used. The SQUARE position channels the square wave output of Q23-Q24 to the pre-amp. When SINE is chosen, the sine shaper output is sent through.

Preamplifier

The preamplifier is a non-inverting closed loop amplifier. Q25 and Q26 form the differential input stage providing dc stability. Q28 forms the second gain stage with Q27 providing the collector of Q28 with a high impedance for increased gain. Q29 buffers the second stage and is the output. Feedback is provided through R101.

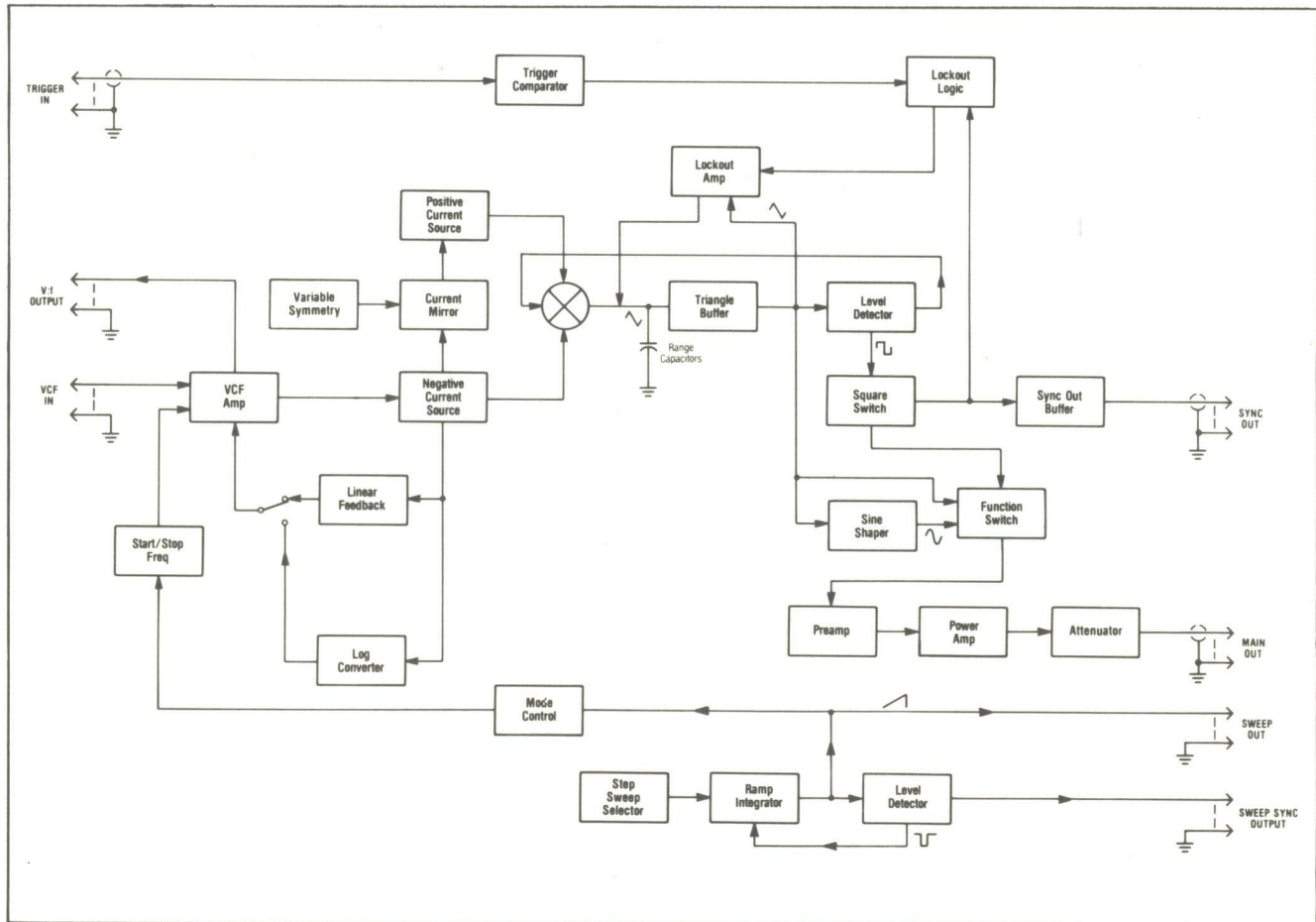

Fig. 12. Block diagram.

Power Amplifier

The power amplifier works much like the preamplifier except that it is inverting, and the second gain stage is buffered by Q34 and Q35 prior to the output stage Q36 and Q37. The ATTENUATOR switches channel the signal through one or more of the divider networks of R519 through R527. This provides 10, 20, or 30 db steps of attenuation or some combination thereof.

Lockout

Lockout is used to gate the 3030 in response to a signal from the TRIGGER IN jack or the MAN switch. The generator is stopped, or locked out, by removing the timing current from capacitor C15. Q302 and Q303 form a differential amplifier with the voltage at the base of Q302 being the lockout voltage. The base of Q303 is connected to the output of the triangle buffer. When the triangle reaches the lockout voltage, Q303 is turned on and the timing current is taken away from the capacitor. The lockout voltage is varied by the START LEVEL control.

Q301 is a current source tracking the positive current source, keeping the lockout level at the same voltage independent of timing current.

Lockout is disabled by pulling the emitters of Q302 and Q303 to 0 volts. This is done by the lockout flip-flop U302C and D. This is a set-reset type flip-flop receiving signals from the trigger comparator and the level detector to enable and disable lockout.

U303 is the trigger comparator. It is a differential comparator set to switch at 1.6 volts with 100 mV of hysteresis. This shapes the incoming trigger signals to levels suitable to drive the flip-flop. U302A and B form a switch debouncer for the manual trigger switch.

The action of U302C and D and the level setting of R302 permits the waveform to always complete a full cycle before lockout occurs.

Sweep

The ramp used for sweeping is generated by integrator U201 and level detector U202. Integrating current is supplied by R605 or R606 from the VAR TIME control. These two resistors, and capacitors C601 and C602, are switched in one of four combinations by the SWEEP TIME switches. This provides four steps of ramp speed, fine tuned by VAR TIME. Reset current is supplied by R207.

U202 senses when the ramp reaches 5 volts and switches to turn on the reset current which rapidly returns the ramp to 0 volts. U202 senses this voltage change and switches again. The ramp peak voltage is set by Q202.

Power Supplies

The ± 20 volt unregulated supplies for the power amplifier are generated from transformer T1, full wave bridge D1 through D4 and filter capacitors C1 and C2. The ± 12 volt regulated supplies are composed of regulators U1 and U2 which regulate the ± 20 volt supplies down to ± 12 volts.

MAINTENANCE AND CALIBRATION

WARNING

1. The following instructions are for use by qualified personnel only. To avoid electric shock, do not perform servicing other than contained in the operating instructions unless you are qualified to do so.
2. A shock hazard is present when the case is removed once the line cord is plugged into an ac outlet. Avoid touching the fuse or bottom of the circuit board in the area of the fuse or power transformer. The fuse has line voltage on it even when the power is turned off.

LINE VOLTAGE SELECTION

The unit is capable of operating from nominal 100 volt, 120 volt, 220 volt, or 240 volt, 50/60 Hz ac power.

The LINE VOLTAGE SELECT switches (25) on the rear panel are simply set to the positions that correspond with the line voltage to be used. Insert a flat blade screwdriver into the slot of each switch and move the slots to align with the graphics indicating the desired voltage (see Fig. 13).

Install correct value fuse, as follows:

100/120 volt ac
operation: 3AG,
1/4 A Slow Blow

220/240 volt ac
operation: 3AG,
1/8 A Slow Blow

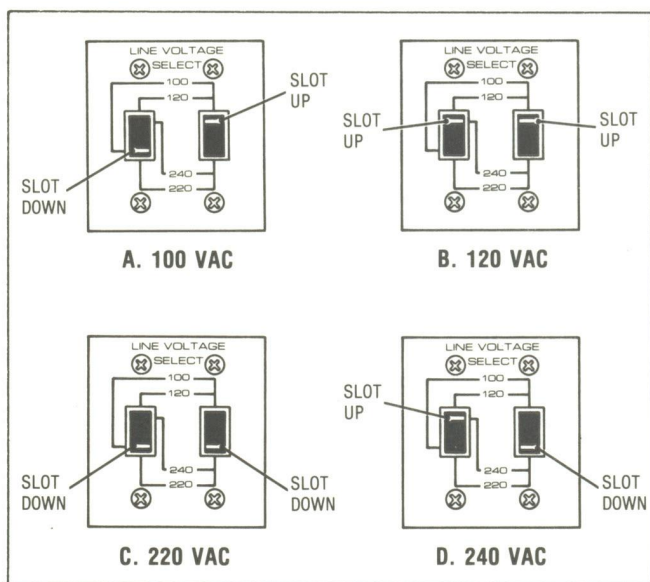

Fig. 13. Line voltage selection.

CALIBRATION ADJUSTMENTS

This unit was carefully checked and calibrated at the factory prior to shipment. Readjustment is recommended only if repairs have been made in a circuit affecting calibration, or if you have reason to believe the unit may be out of calibration. Complete recalibration procedures are given in this manual. However, calibration adjustments should be attempted only if the proper test equipment is available, and you are experienced and qualified in its use. If the accuracy of the test equipment used for calibration is less than specified, the accuracy of the 3030 will be proportionately degraded. Perform related adjustments in the specified sequence to avoid any undesirable interaction of adjustments. Locations of calibration adjustments are given in Fig. 14.

TEST EQUIPMENT REQUIRED

Oscilloscope, dc-35 MHz, risetime 12 ns or less, vertical sensitivity 10 mV per division, B & K-Precision Model 1479B or equivalent.

Counter-timer, 1 Hz to 5 MHz with time interval A to B.

Distortion Analyzer, less than 0.1% residual distortion.

PROCEDURE

Initial Control Settings

Set the front panel controls as follows:

MAINTENANCE AND CALIBRATION

LIN/LOG	Disengaged
RUN	Engaged
GATE	Disengaged
RANGE-Hz	10K
SWEEP	Disengaged
STOP	Disengaged
STOP FREQ	Midrange
FUNCTION	SQUARE
DC OFFSET	OFF
AMPLITUDE	Fully clockwise
VAR SYM	Fully counterclockwise
VAR TIME	Fully counterclockwise
START FREQ	1.0

Buffer Offset Adjustment

1. Connect oscilloscope to TP1.
2. Adjust BUF DC for a symmetrical triangle around 0 V \pm 100 mV.
3. Disconnect oscilloscope.

Time Symmetry Adjustment

1. Connect MAIN OUTPUT to counter-timer.
2. Set counter-timer to measure time interval.

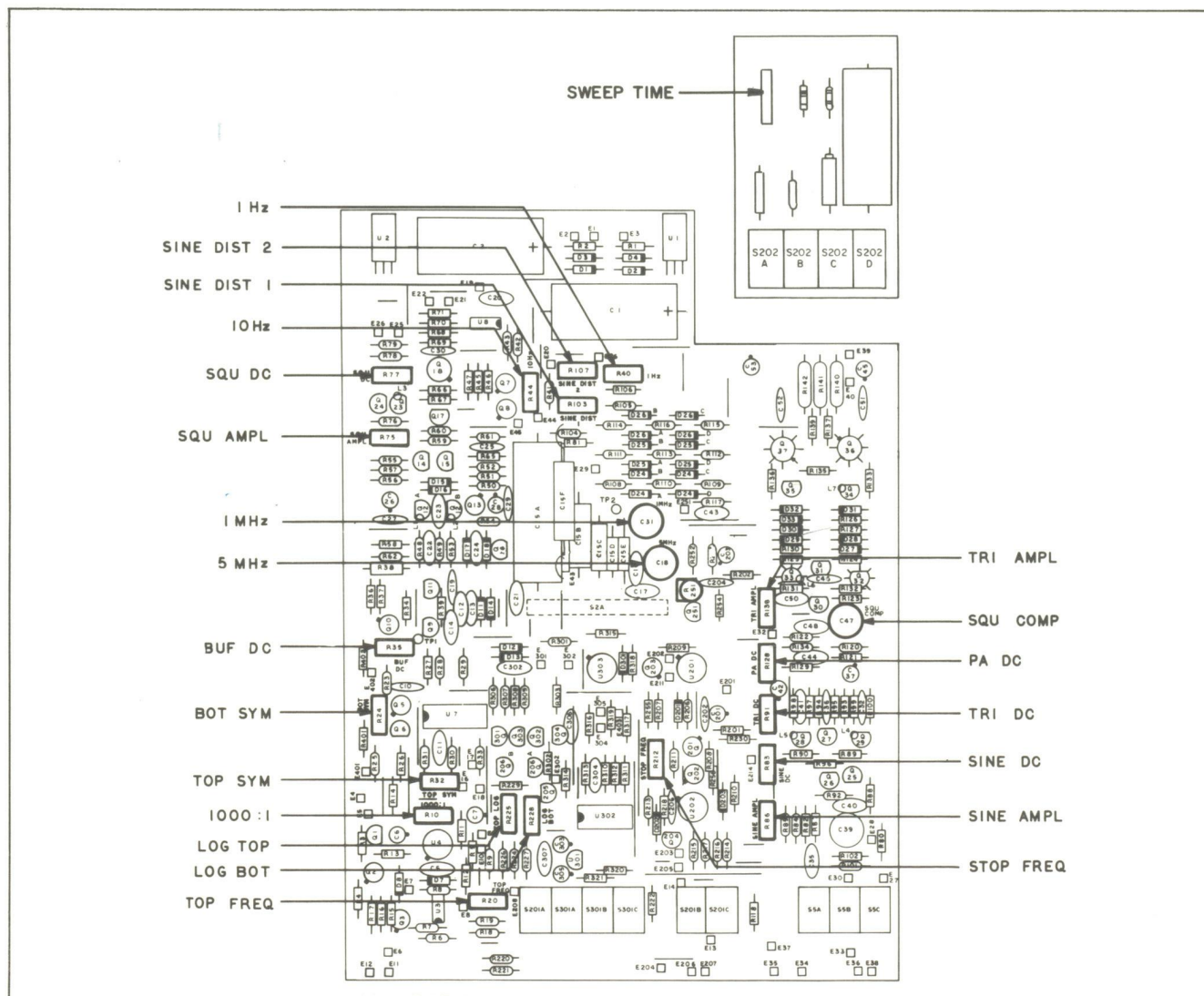

Fig. 14. Calibration adjustment locations.

3. Set START FREQ for a reading of approximately 75 μ s.
4. Alternately switch the counter-timer to measure the two halves of the waveform separately (positive edge to negative edge, then negative to positive).
5. Adjust TOP SYM for both halves to be the same $\pm 0.1\%$ (± 75 ns).
6. Set START FREQ for a counter reading of approximately 5 ms. If dial will not adjust low enough in period, vary 1000:1 Do not change ranges.
7. Adjust BOT SYM as in steps 4 and 5 above.
8. Repeat steps 3 through 7 until no further improvement can be obtained.

Frequency Adjustment

1. Set START FREQ outer dial to S, inner dial fully counterclockwise, and RANGE-Hz to 10K.
2. Set counter to measure frequency (or period for low frequency adjustments).
3. Adjust 1000:1 for a frequency of 8 Hz ± 0.8 Hz (125 ms ± 12 ms).
4. Set START FREQ to 1.0.
5. Adjust TOP FREQ for 10 kHz.
6. Set RANGE-Hz to 1.
7. Adjust 1 Hz for 1 Hz ± 0.01 Hz (1 s ± 10 ms).
8. Set RANGE-Hz to 10.
9. Adjust 10 Hz for 10 Hz ± 0.1 Hz (0.1 s ± 1 ms).
10. Set RANGE-Hz to 1M.
11. Adjust 1 MHz for 1 MHz ± 10 kHz.
12. Set RANGE-Hz to 5M.

13. Adjust 5 MHz for 5 MHz ± 50 kHz.

Log Scale Adjustment

1. Depress LOG.
2. Set RANGE-Hz to 10K.
3. Adjust LOG TOP for 10 kHz ± 100 Hz (100 μ s ± 1 μ s).
4. Turn START FREQ outer dial to S and inner dial fully counterclockwise.
5. Adjust LOG BOT for 0.8 Hz ± 0.08 Hz (1.25 s ± 125 ms).
6. Repeat steps 3 through 5 until no further improvement can be obtained.
7. Disengage LOG.

Sine Wave Distortion

1. Set FUNCTION to SINE.
2. Set RANGE-Hz to 10K.
3. Set START FREQ to 1.0.
4. Connect MAIN OUTPUT to distortion analyzer.
5. Adjust SINE DIST 1 and SINE DIST 2 for minimum distortion. Repeat until no further improvement can be obtained.

Output Level Adjustment

1. Connect MAIN OUTPUT to oscilloscope terminated in 50 Ω .
2. Turn AMPLITUDE fully counterclockwise.
3. Set FUNCTION to TRIANGLE.
4. Adjust PA DC for 0 V dc ± 10 mV.
5. Turn AMPLITUDE fully clockwise.
6. Adjust TRI DC for a dc offset of 0 V ± 10 mV.

MAINTENANCE AND CALIBRATION

7. Adjust TRI AMPL for triangle peaks of +5.1 V and -5.1 V \pm 50 mV.
8. Set FUNCTION to SINE.
9. Adjust SINE DC for a dc offset of 0 V \pm 10 mV.
10. Adjust SINE AMPL for sine peaks of +5.1 V and -5.1 V \pm 50 mV.
11. Set FUNCTION to SQUARE.
12. Adjust SQU DC for positive square wave peaks of +5.1 V \pm 50 mV.
13. Adjust SQU AMPL for negative square wave peaks of -5.1 V \pm 50 mV.

Rise Time Adjustment

1. Set START FREQ to .7.
2. Set RANGE-Hz to 1M.
3. Adjust SQU COMP for rise and fall times less than 50 ns and overshoot and ringing less than 5%.

Sweep Adjustment

1. Engage RUN.

2. Engage SWEEP.
3. Engage STOP.
4. Set START FREQ to S.
5. Adjust STOP FREQ for minimum change in frequency as START FREQ is rotated.
6. Disengage STOP.

Sweep Time Adjustment

1. Engage RUN.
2. Engage SWEEP.
3. Engage 10 ms SWEEP TIME (front panel).
4. Connect SWEEP OUT to oscilloscope vertical input.
5. Connect SWEEP SYNC OUT to oscilloscope external trigger; obtain stable display of sweep ramp.
6. Set VAR TIME to full counterclockwise position (CAL).
7. Adjust SWEEP TIME (Fig. 14) for exactly 10 ms sawtooth on scope.

WARRANTY INFORMATION

WARRANTY SERVICE INSTRUCTIONS

1. Refer to the MAINTENANCE section of your **B & K-Precision** instruction manual for adjustments that may be applicable.
2. If the above-mentioned does not correct the problem you are experiencing with your unit, pack it securely (preferably in the original carton or double-packed). Enclose a letter describing the problem and include your name and address. Deliver to, or ship PREPAID (UPS preferred) to the nearest **B & K-Precision** authorized service agency (see list enclosed with unit).

If your list of authorized **B & K-Precision** service agencies has been misplaced, contact your distributor for the name of your nearest service agency, or write to:

Service Department
B & K-Precision Product Group
DYNASCAN CORPORATION
2815 West Irving Park Road
Chicago, Illinois 60618

LIMITED ONE-YEAR WARRANTY

DYNASCAN CORPORATION warrants to the original purchaser that its **B & K-Precision** product, and the component parts thereof, will be free from defects in workmanship and materials for a period of one year from the date of purchase.

DYNASCAN will, without charge, repair or replace, at its option, defective product or component parts upon delivery to an authorized **B & K-Precision** service contractor or the factory service department, accompanied by proof of purchase date in the form of a sales receipt.

To obtain warranty coverage, this product must be registered by completing and mailing the enclosed warranty registration card to DYNASCAN, **B & K-Precision**, 6460 West Cortland Street, Chicago, Illinois 60635 within fifteen (15) days from the date of purchase.

Exclusions: This warranty does not apply in the event of misuse or abuse of the product or as a result of unauthorized alterations or repairs. It is void if the serial number is altered, defaced or removed.

DYNASCAN shall not be liable for any consequential damages, including without limitation damages resulting from loss of use. Some states do not allow limitation of incidental or consequential damages, so the above limitation or exclusion may not apply to you.

This warranty gives you specific rights and you may also have other rights which vary from state to state.

For your convenience we suggest you contact your **B & K-Precision** distributor, who may be authorized to make repairs or can refer you to the nearest service contractor. If warranty service cannot be obtained locally, please send the unit to **B & K-Precision** Service Department, 2815 West Irving Park Road, Chicago, Illinois 60618, properly packaged to avoid damage in shipment.

ACCESSORIES

ACCESSORIES SUPPLIED:

Power Cord
Instruction Manual
Composite (Schematic and Parts List)

OPTIONAL ACCESSORIES AVAILABLE:

B & K-Precision Cables:

Model	Description
CC-41	36" RG/58U coax, BNC on each end.
CC-42	36" RG/58U coax, BNC to UHF (PL-259)
CC-43	36" RG/58U coax, BNC to dual banana plugs.
CC-44	36" RG/58U coax, BNC to microphone connector.
CC-45	36" RG/58U coax, BNC to type N.

B+K PRECISION DYNASCAN
CORPORATION

6460 West Cortland Street
Chicago, Illinois 60635

© 1981 • DYNASCAN CORP.

